

1. 机壳、外装分组件/Machine frame & cover components

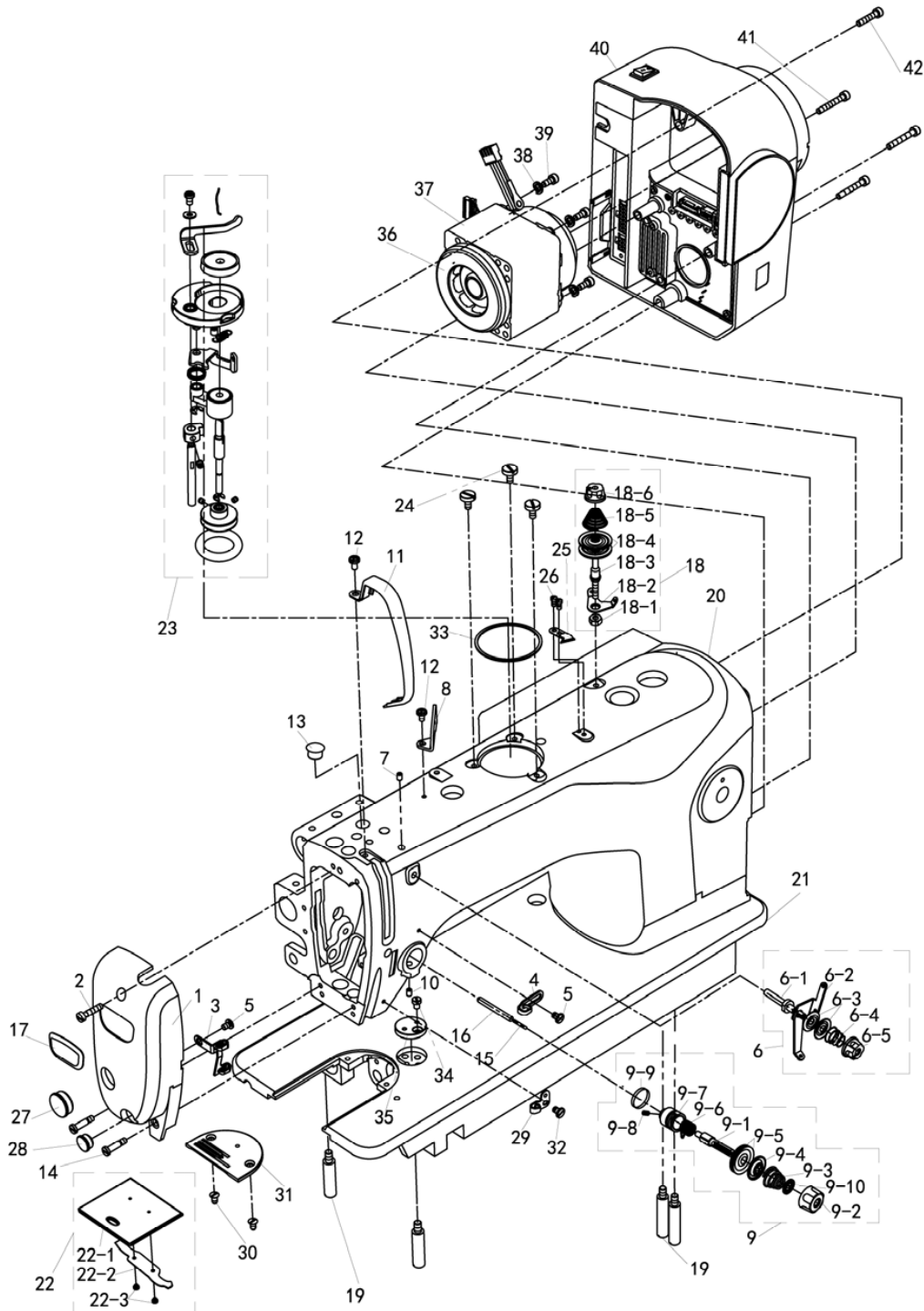

1.机壳、外装分组件/Machine frame & cover components

序号 NO.	公司件号 Part NO.	名称 Part Name	零件描述 Description	数量 Number		
				CZ	CZZD	CZ-12
1	304713	面板	Panel	1	1	
	930000235	面板(12mm)	Panel (12mm)			1
2	201511025	面板螺钉	Panel Screw SM11/64×40	1	1	1
3	14713003	面板线勾	Panel thread guide	1	1	1
4	10113004	右线钩	Panel thread guide (right)	1	1	1
5	101511007	螺钉 SM11/64×40×6	Screw SM11/64×40×6	2	2	2
6	1411300400	小夹线器组件	Small thread tension assay	1	1	1
6-1	13812066	过线板	Thread tension guide plate	1	1	1
6-2	13810008	小夹线器螺柱	Thread tension bolt	1	1	1
6-3	11212004	小夹线板	Thread tension disk	2	2	2
6-4	11227001	小夹线弹簧	Thread tension spring	1	1	1
6-5	138516019	小夹线器螺母	Thread tension nut	1	1	1
7	113514002	小夹线固定螺钉	Set Screw	1	1	1
8	13512004	三孔线勾	3-hole thread guide	1	1	1
9	11471300100	夹线组件	Thread tension assay	1	1	1
9-1	1147NS30001	夹线螺钉	Thread tension Screw	1	1	1
9-2	141516013	夹线螺母	Thread tension nut	1	1	1
9-3	14227024	夹线弹簧	Thread tension spring	1	1	1
9-4	10112006	松线板	Tension releasing board	1	1	1
9-5	14112015	夹线板	Thread tension disk	2	2	2
9-6	114727001	挑线簧	Take-up spring	1	1	1
9-7	13513006	夹线调节座	Thread tension retainer	1	1	1
9-8	135515002	夹线调节座螺钉	Screw	1	1	1
9-9	001050	O 型圈	O Ring 14.5x1.5	1	1	1
9-10	10112007	夹线螺母止动板	Thread tension nut locking plate	1	1	1
10	136514002	螺钉 SM15/64 X 28	Screw SM15/64 X 28	1	1	1
11	14712018	挑线杆防护罩	Thread take-up lever cover	1	1	1
12	101511004	螺钉 SM3/16X28 X7	Screw SM3/16X28 X7	2	2	2
13	10122005	挑线连杆销螺孔塞	Take-up link pin screw plug	1	1	1
14	135511047	面板螺钉 SM11/64×40	Panel Screw SM11/64×40	2	2	2
15	14726001	松线钉	Thread release pin	1	1	1
16	13502018	松线棒	Thread release bar	1	1	1
17	13837002	A4-0182 商标牌	A4-0182 trademark	1	1	1
18	1411300600	绕线夹线器	Bobbin winder thread tension	1	1	1
18-1	114516001	螺母 SM11/64×40	Nut SM11/64×40	1	1	1
18-2	11413022	夹线过线板	Thread tension guide plate	1	1	1
18-3	13601006	夹线螺钉	Screw	1	1	1
18-4	10112005	夹线板	Thread tension disk	2	2	2
18-5	11427006	小夹线弹簧	Spring	1	1	1
18-6	138516019	小夹线器螺母	Thread tension nut	1	1	1
19	101512001	底板支柱	Base plate pillar	4	4	4
20	100968	H5 机壳	H5 frame	1	1	1
21	100767	底板	Base plate	1	1	1
22-1	13515002	推板	Slide plate	1	1	1
22-2	13512007	推板簧	Slide plate spring	1	1	1
22-3	101511019	螺钉 SM3/32×56 L=2	Screw SM3/32×56 L=2	2	2	2
23	1473100100	绕线器组件	Bobbin winder thread tension	1	1	1
24	114511003	开槽圆柱头螺钉	Screw	3	3	3
25	11419001	切线刀	Thread cutter	1	1	1
26	114511015	螺钉 SM9/64×40 L=6	SCREW SM9/64×40 L=6	2	2	2
27	13522001	面板橡皮塞 (Φ19)	Rubber plug(Φ19)	1	1	1

1.机壳、外装分组件/Machine frame & cover components

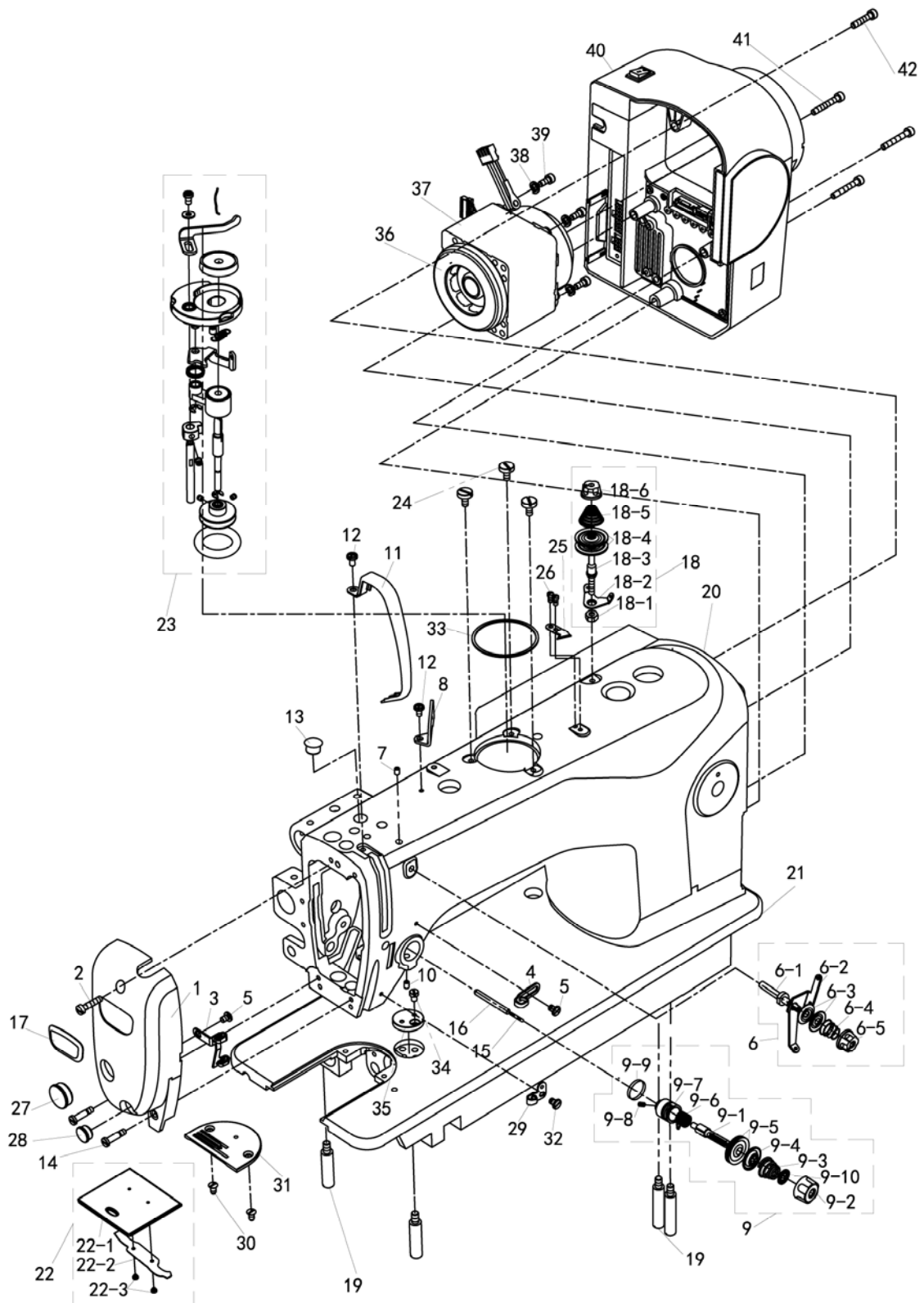

1.机壳、外装分组件/Machine frame & cover components

序号 NO.	公司件号 Part NO.	名称 Part Name	零件描述 Description	数量 Number		
				CZ	CZZD	CZ-12
28	13522002	面板橡皮塞 (Φ11.8)	Rubber plug (Φ11.8)	1	1	1
29	13513010	下勾线	Nest less e-device	1	1	1
30	101S17002	螺钉 SM11/64×40 L=5	Screw SM11/64×40 L=5	2	2	2
31	13515001	针板	Needle plate	1		1
	13615003	针板 (12mm)	Needle plate (12mm)		1	
32	101S11005	螺钉	Screw	1	1	1
33	11422062	密封垫	Gland	1	1	1
34	101S11025	螺钉 SM11/64×40×7	Screw SM11/64×40×7	2	2	2
35	13512001	卷边器座	Beadier pedestal	1	1	1
36	13811060	电机绝缘防护罩	Motor insulation shield	1	1	1
37	1363303000	光电伺服电机	Motor	1	1	1
38	W02004	弹簧垫圈	Spring washer	4	4	4
39		螺钉 M5×70	Screw M5×70	4	4	4
40	1473304200	功能型电控	Machine electric control	1	1	1
41	114S13001	螺钉 M5×20	Screw M5×20	1	1	1
42	136S13001	螺钉 M5×35	Screw M5×35	3	3	3

2. 上轴挑线分组件/Main shaft & thread take-up components

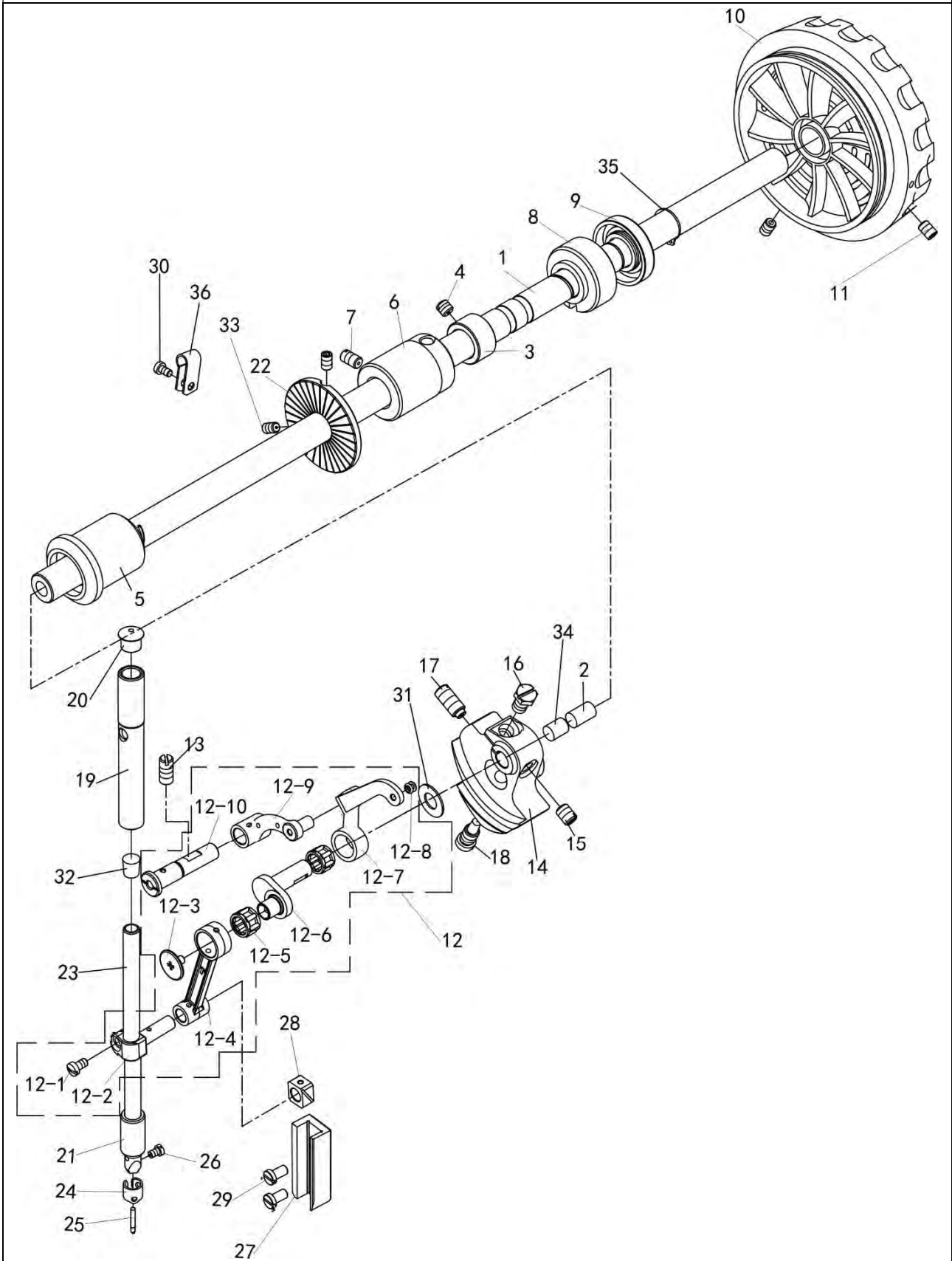

2.上轴挑线分组件/Main shaft & thread take-up components

序号 NO.	公司件号 Part NO.	名称 PartName	零件描述 Description	数量 Number		
				CZZD	1	CZ-12
1	14702011	上轴	Main shaft	1	1	1
2	10122012	上轴橡皮塞	Rubber plug	1	1	1
3	10108003	上轴紧圈	Shaft washer	1	1	1
4	101S15002	螺钉 SM1/4×40×6	Screw SM1/4×40×6	2	2	2
5	13603023	上轴前轴套	Main shaft bushing front	1	1	1
6	13503017	上轴中轴套	Main shaft bushing, middle	1	1	1
7	135S15006	螺钉 SM15/64×28	Screw SM15/64×28	1	1	1
8	13603027	上轴后套	Main shaft bushing back	1	1	1
9	13522010	上轴后轴套油封组件	Bushing back oil seal assay	1	1	1
10	304714	主动轮	Capstan	1	1	1
11	S10009	主动轮螺钉 M6x8	Capstan Screw M6x8	2	2	2
12	1353800200	挑线杆组件	Thread take-up assay	1	1	1
12-1	101S11005	开槽球面圆柱头螺钉	Screw SM11/64×40×8	1	1	1
12-2	13505002	针杆接头	Needle bar connection	1	1	1
12-3	101S17001	挑线曲柄螺钉 (左旋)	Screw	1	1	1
12-4	13505003	针杆连杆	Needle bar connecting rod	1	1	1
12-5	10124001	挑线杆滚针轴承	Needle bearing	1	1	1
12-6	13504002	挑线杆曲柄	Thread take-up crank	1	1	1
12-7	13538004	挑线杆	Thread take-up rod	1	1	1
12-8	13538003	挑线杆衬套	Thread take-up bushing	1	1	1
12-9	13538002	挑线连杆	Thread take-up connecting rod	1	1	1
12-	13502003	挑线连杆铰链销	Pin	1	1	1
13	135S15009	螺钉 SM15/64×28	Screw SM15/64×28	1	1	1
14	114704013	针杆曲柄	Needle bar crank	1	1	1
15	101S15007	螺钉 SM1/4×40×8	Screw SM1/4×40×8	1	1	1
16	101S15007	螺钉 SM1/4×40×8	Screw SM1/4×40×8	1	1	1
17	101S15004	螺钉 SM9/32×28×16	Screw SM9/32×28×16	1	1	1
18	135S11002	螺钉 SM9/32×28	Screw SM9/32×28	1	1	1
19	14703006	针杆上衬套	Needle bar upper bushing	1	1	1
20	10122013	针杆上衬套橡皮塞	Upper bushing rubber plug	1	1	1
21	13503007	针杆下衬套	Needle bar lower bushing	1	1	1
22	14735001	驱动轮	BTW-DRIVING-WHEEL	1	1	1
23	13602002	针杆	Needle bar	1	1	1
24	13513011	针杆过线环	Needle bar thread ring	1	1	1
25	13517001	机针(DP×17 23#)	Needle(DP×17 23#)	1	1	1
26	101S11006	螺钉 SM1/8×44 L=4.5	Screw SM1/8×44 L=4.5	1	1	1
27	13609001	滑块槽	Slider trough	1	1	1
28	11409001	针杆接头滑块	Connection Slider	1	1	1
29	101S11008	滑块导轨螺钉	Slider guide rail Screw	2	2	2
30	101S11005	螺钉 SM11/64×40×8	Screw SM11/64×40×8	2	2	2
31	10112003	垫片	Washer	1	1	1
32	13523001	毛毡	Oil felt for needle bar	1	1	1
33	S10035	螺钉 M5×8	Screw M5×8	2	2	2
34	114723001	针杆上毡塞	Oil felt for needle bar	1	1	1
35	H03001	轴用弹性挡圈 15	Washer	1	1	1
36	40511001	线夹	Wire clip	2	2	2

3. 压料分组件/Presser bar components

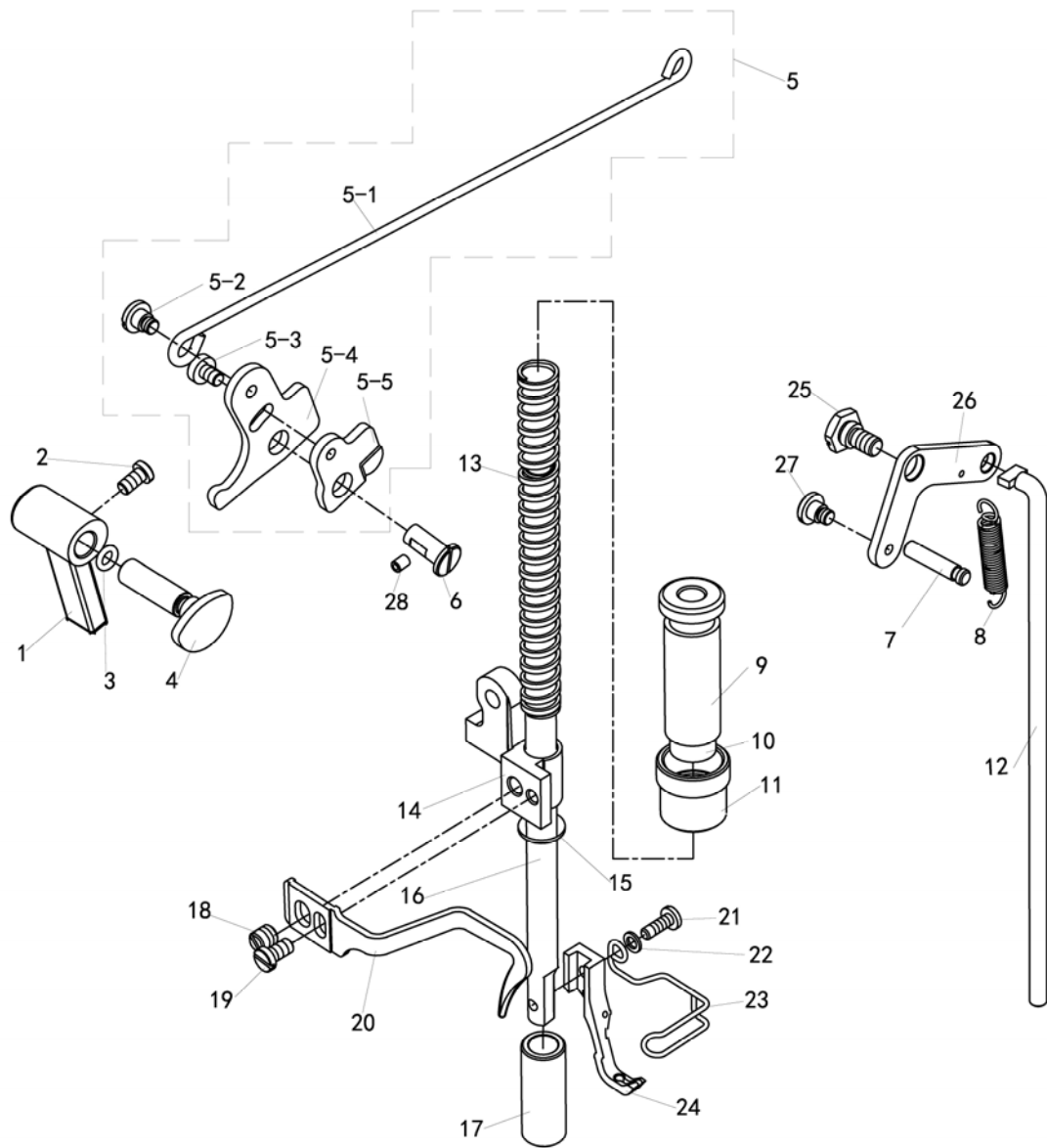

3.压料分组件/Presser bar components

序号 NO.	公司件号 Part NO.	名称 Part Name	零件描述 Description	数量 Number		
				CZ	CZZD	CZ-12
1	14711005	压脚扳手	Presser foot wrench	1	1	1
2	101S11008	螺钉 SM11/64×40×8	Screw SM11/64×40×8	1	1	1
3	001009	O 型圈 4.5X1.8	O-ring 4.5X1.8	1	1	1
4	13510004	压紧杆提升凸轮	Presser bar lifting cam	1	1	1
5	1351201200	膝腔提升杠杆(左)组件	Knee lifter lever (left) assy	1	1	1
5-1	13512014	膝腔提升拉杆	Knee lifter rod	1	1	1
5-2	135S11027	螺钉 SM3/16×28	Screw SM3/16×28	1	1	1
5-3	135S11026	螺钉 SM11/64×40	Screw SM11/64×40	1	1	1
5-4	13512013	膝腔提升杠杆(左)	Knee lifter lever (left)	1	1	1
5-5	13510005	松线凸轮	Tension releasing cam	1	1	1
6	114726007	松线凸轮销	Enstion releasing cam melt	1	1	1
7	13526005	弹簧销	Pin for spring	1	1	1
8	13527010	膝腔提升杠杆(右)弹簧	Presser spring	1	1	1
9	1147N530003	螺钉 M15×1	Screw M15×1	1	1	1
10	114709002	调压螺钉导套	Guide bushing	1	1	1
11	135S16003	螺母 M15×1	Nut M15×1	1	1	1
12	13512016	膝腔提升杠杆	Knee lifter lever	1	1	1
13	13527011	压紧杆弹簧	Presser spring	1	1	1
14	114709001	压紧杆导架(加轴承)	Presser bar lifting bracket	1	1	1
15	30122022	压脚轴碟形密封圈	Gasket	1	1	1
16	13502019	压紧杆	Presser bar	1	1	1
17	13503013	压紧杆轴套	Presser bar bushing	1	1	1
18	101S15006	螺钉 SM15/64×28	Screw SM15/64×28	1	1	1
19	101S11008	螺钉 SM11/64×40×8	Screw SM11/64×40×8	1	1	1
20	114713002	大线勾	thread guide	1	1	1
21	101S11009	螺钉 SM9/64×40×10.5	Screw SM9/64×40×10.5	1	1	1
22	13528007	小压脚螺钉垫片	Washer	1	1	1
23	13512017	防护勾	Defend hook	1	1	1
24	13516001	小压脚	Presser foot complete	1		1
	13516005	小压脚	Presser foot complete		1	
25	135S12002	螺钉 SM15/64×28	Screw SM15/64×28	1	1	1
26	13512015	膝腔提升杠杆(右)	Knee lifter lever (right)	1	1	1
27	135S11027	螺钉 SM3/16×28	Screw SM3/16×28	1	1	1
28	113S14020	螺钉 SM11/64×40	Screw SM11/64×40	1	1	1

4. 送料分组件/Feed mechanism components

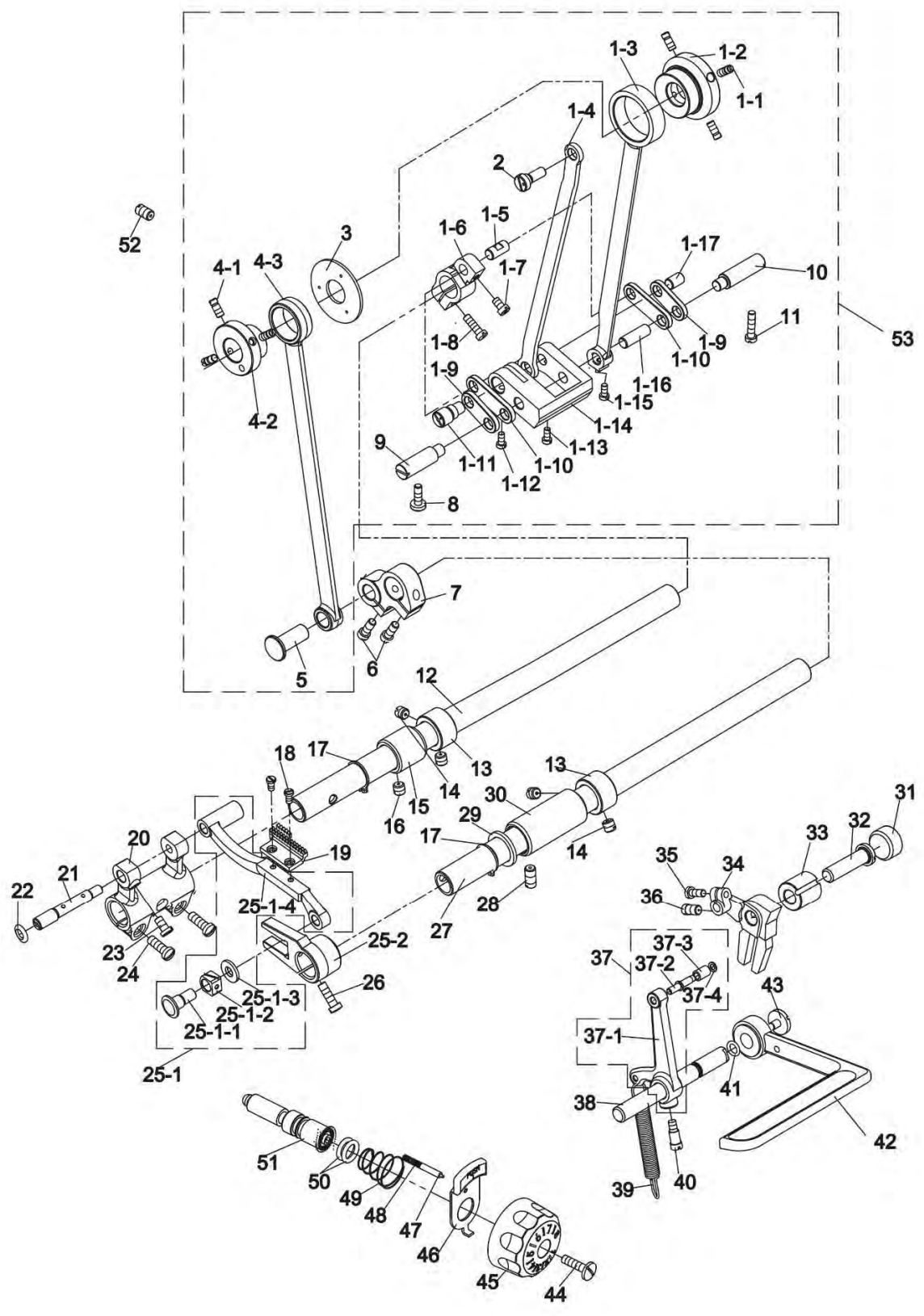

4.送料分组件/Feed mechanism components

序号 NO.	公司件号 Part NO.	名称 Part Name	零件描述 Description	数量 Number		
				CZ	CZZD	CZ-12
1	1350501500	送布连杆组件	Rocker shaft connecting rod assy	1	1	1
1-1	135515007	送布凸轮螺钉	Screw	3	3	3
1-2	13510003	送布凸轮	Feed drive eccentric cam.	1	1	1
1-3	13505005	送布连杆	Rocker shaft connecting rod	1	1	1
1-4	13505006	针距调节连杆	Feed regulator connecting rod	1	1	1
1-5	13526001	送布曲柄短销	Walking foot crank short pin	1	1	1
1-6	13504004	送布曲柄 (右)	Feed rocker shaft crank assembly	1	1	1
1-7	101511025	螺钉 SM11/64×40×7	Screw SM11/64×40×7	1	1	1
1-8	409511021	螺钉 SM11/64×40×14	Screw SM11/64×40×14	1	1	1
1-9	13505024	曲柄短连杆	Connecting short link	2	2	2
1-10	13505023	曲柄长连杆	Crank long link	2	2	2
1-11	13502015	连杆偏心轴	Hinge pin	1	1	1
1-12	201511007	螺钉 SM9/64X40	Screw SM9/64X40	1	1	1
1-13	201511012	螺钉 SM9/64X40	Screw SM9/64X40	1	1	1
1-14	13504007	针距调节曲柄	Needle pitch adjusting link	1	1	1
1-15	209514008	螺钉 SM11/64×40×4.5	Screw SM11/64×40×4.5	1	1	1
1-16	13502014	曲柄连杆长销	Crank connecting pin	1	1	1
1-17	13526003	曲柄连杆短销	Crank connecting pin	1	1	1
2	13510002	针距调节连接销钉	Hinge pin	1	1	1
3	13528002	凸轮隔离片	Thrust collar	1	1	1
4	11350500200	拾牙连杆组件	Connecting rod assembly	1	1	1
4-1	135515007	螺钉 SM11/64×40	Screw SM11/64×40	3	3	3
4-2	13510001	拾牙凸轮	Feed drive eccentric cam.	1	1	1
4-3	13505001	拾牙连杆	Connecting rod	1	1	1
5	13502009	拾牙曲柄铰链轴	Hinge pin	1	1	1
6	135511048	螺钉 SM3/16×32	Screw SM3/16×32	2	2	2
	409511015	螺钉 SM3/16×28×15.5	Screw SM3/16×28×15.5	1	1	1
7	13504019	拾牙右曲柄	Feed lifting rock shaft crank(right)	1	1	1
8	105511019	螺钉 SM11/64×40 L=13	Screw SM11/64×40 L=13	1	1	1
9	13502016	针距调节曲柄定位销	Adjusting link fulcrum shaft	1	1	1
10	13502017	针距调节曲柄定位销	Adjusting link fulcrum shaft pin	1	1	1
11	114511004	螺钉 SM11/64×40×18	Screw SM 11/64×40×18	1	1	1
12	13602003	送布轴	Feed rocker shaft	1	1	1
13	10108003	拾牙、送布轴紧圈	Thrust collar assay	2	2	2
14	101515002	螺钉 SM1/4×40×6	Screw SM1/4×40×6	4	4	4
15	13603024	送布轴前轴套	Bushing for feed rock shaft(right)	1	1	1
16	135515009	螺钉 SM15/64×28	Screw SM15/64×28	1	1	1
17	H03001	轴用弹性挡圈	Retaining ring	2	2	2
18	101511018	螺钉 SM1/8×40 L=6	Screw SM1/8×40 L=6	2	2	2
19	13514001	送布牙	Feed dog	1	1	
	13614003	送布牙(12MM)	Feed dog(12MM)			1
20	13504003	牙架曲柄	Feed crank assembly	1	1	1
21	13502005	牙架曲柄偏心轴	Feed bar shaft	1	1	1
22	13528004	牙架垫圈	Washer	1	1	1
23	101511008	螺钉 SM11/64×40×8	Screw SM11/64×40×8	1	1	1
24	101511016	螺钉 SM3/16×28 L=14	Screw SM3/16×28 L=14	2	2	2
25-1	1350700300	牙架组件	Feed bar assembly	1	1	1
25-	13502029	牙架连接销	Feed pin	1	1	1

4. 送料分组件/Feed mechanism components

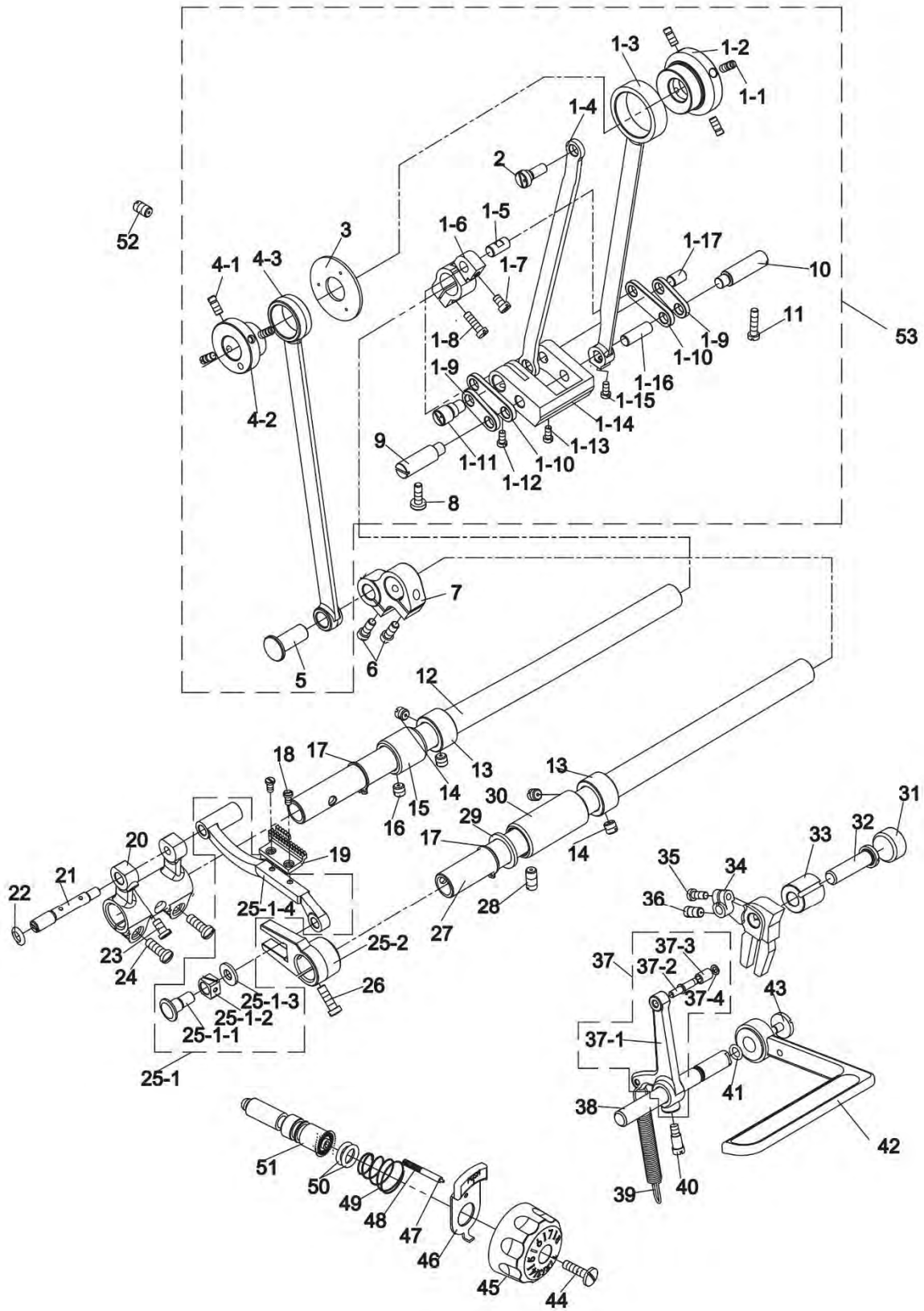

4.送料分组件/Feed mechanism components

序号 NO.	公司件号 Part NO.	名称 Part Name	零件描述 Description	数量 Number		
				CZ	CZZD	CZ-12
25-1-2	13509007	滑块	Slider	1	1	1
25-1-3	13528009	垫片	washer	1	1	1
25-1-4	13507001	牙架	Feed bar assembly	1	1	1
25-2	13505004	拾牙叉	Feed forked connection	1	1	
	13505018	拾牙叉(12mm)	Feed forked connection(12mm)			1
26	409511021	拾牙叉夹紧螺钉	Screw	1	1	1
27	13602004	拾牙轴	Feed lifting rock shaft	1	1	1
28	135515008	拾牙轴前轴套螺钉	Screw	1	1	1
29	13528006	垫圈	Washer	1	1	1
30	13603005	拾牙轴前轴套	Bushing for feed rock shaft(right)	1	1	1
31	13522014	橡皮塞(φ19.5)	Rubber plug (φ 19.5)	1	1	1
32	13502011	针距座轴	Hinge pin for feed regulator	1	1	1
33	13503026	针距座衬套	Feed regulator bushing	1	1	1
34	13509003	针距座	Feed regulator	1	1	
	13509003	针距座(12mm)	Feed regulator(12mm)			1
35	101511020	螺钉 SM11/64×40	Screw SM11/64×40 L=10.5	1	1	1
36	135511009	螺钉 SM15/64×28	Screw SM15/64×28	1	1	1
37	1350401400	倒缝操作杆曲柄组件	Slide block pin	1	1	1
37-1	13504006	倒缝操作杆曲柄	Inverted seam lever crank	1	1	1
37-2	13502012	操作杆曲柄滚柱销	Operating rod crank roller pin	1	1	1
37-3	13509006	滚柱	Roller columnn	1	1	1
37-4	13509010	垫片	Washer	1	1	1
38	13502013	倒缝扳手轴	Reverse feed lever shaft	1	1	1
39	13527007	曲柄弹簧	Spring for feed crank	1	1	
	13527016	曲柄弹簧(12mm)	Spring for feed crank(12mm)			1
40	135515014	螺钉 SM15/64×28	Screw SM15/64×28	1	1	1
41	001137	O 型圈 Φ6.3×1.8	O-ring Φ6.3×1.8	1	1	1
42	13531001	倒缝扳手	Reverse feed lever	1	1	1
43	135511022	螺钉 SM3/16×32	Screw SM3/16×32	1	1	1
44	101511022	螺钉 SM3/16×28×18	Dial screw SM3/16×28×18	1	1	1
45	1471100200	针距盘	Needle pitch dial	1	1	
	11471100200	针距盘(12mm)	Needle pitch dial (12mm)			1
46	14212068	针距按键	Feed regulator key-press	1	1	1
47	112326008	止动销	Stopper pin	1	1	1
48	11427034	止动销弹簧	Spring for stopper pin	1	1	1
49	13527009	针距按键簧	Dial spring for key-press	1	1	1
50	001046	O 型圈Φ9.5×2.5	O-ringΦ9.5×2.5	2	2	2
51	136530004	针距调节螺杆	Feed regulator screw bar	1	1	1
52	135515006	上轴中套螺钉	Pin bushing	1	1	1
53	1135050010	送布拾牙连杆组件	Rocker shaft connecting rod assy	1	1	1

5.上送料部件/Upper feed Parts

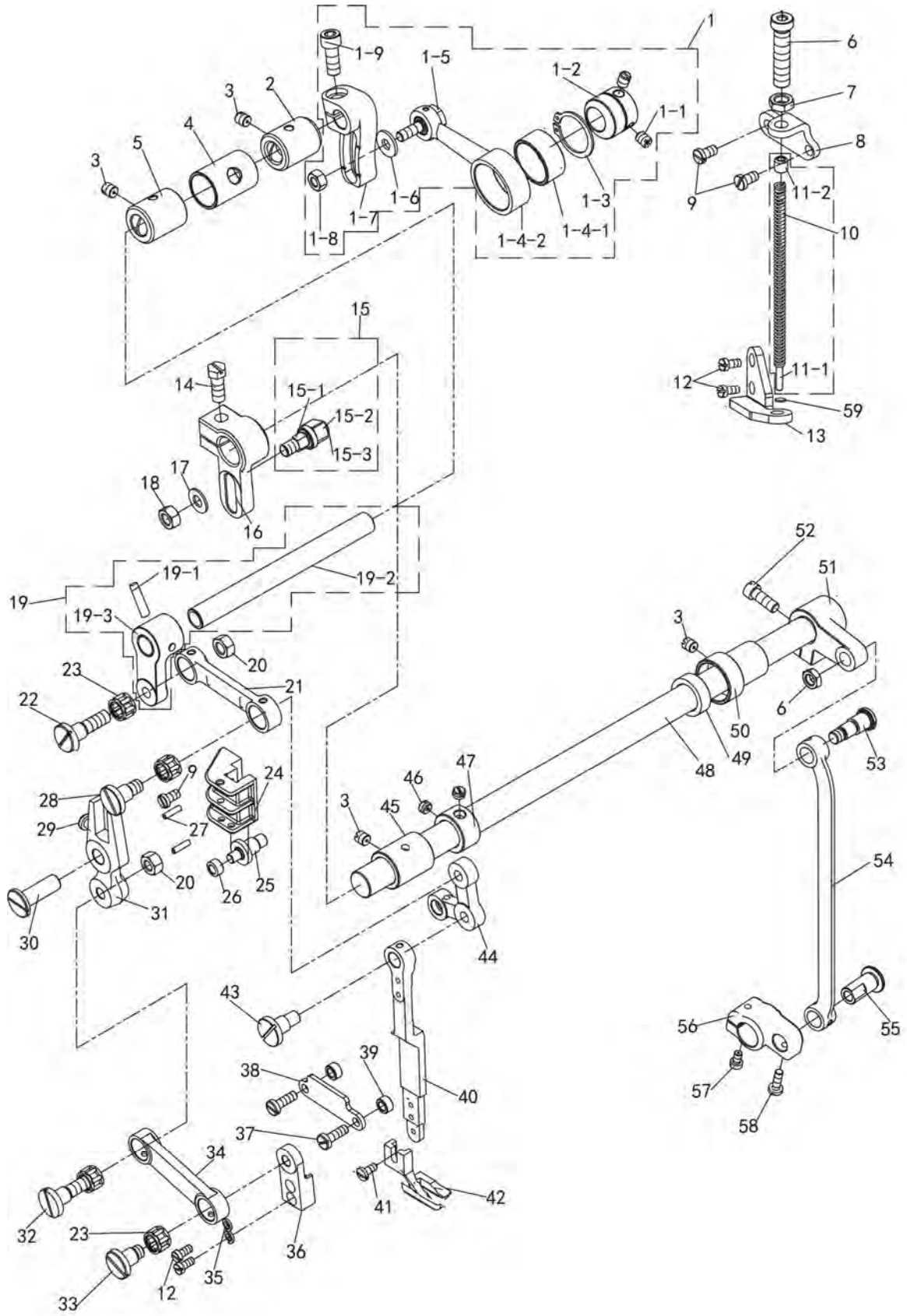

5.上送料部件/Upper feed Parts

序号 NO.	公司件号 Part NO.	名称 Part Name	零件描述 Description	数量 Number		
				CZ	CZZD	CZ-12
1	11470500200	连杆组件	Connecting rod assembly	1		1
	11470500700	连杆组件(4.5mm)	Connecting rod(4.5mm)		1	
1-1	101515007	螺钉 SM1/4×40×8	Screw SM1/4×40×8	2	2	2
1-2	114710001	压脚升降偏心轮	Eccentric wheel	1		1
	114710003	压脚升降偏心轮(4.5mm)	Eccentric wheel(4.5mm)		1	
1-3	H03061	轴用弹性挡圈 24	Retaining ring 24	1		1
		轴用弹性挡圈 26	Retaining ring 26		1	
1-4	11470500300	连杆小组件	Connecting rod widget	1		1
	11470500800	连杆小组件(4.5mm)	Connecting rod widget(4.5mm)		1	
1-4-1	114703001	提升连杆衬套	Bushing	1	1	1
1-4-2	114705001	提升连杆	Lifting link	1	1	1
1-5	135520006	螺钉 M6×0.75	Screw M6×0.75	1	1	1
1-6	13528008	垫圈	Washer	1	1	1
1-7	13504013	偏心连杆调节曲柄	Presser lifting shaft	1	1	1
1-8	N02001	六角螺母 M6X0.75	Hex nut M6X0.75	1	1	1
1-9	135511035	螺钉 SM1/4×24	Screw SM1/4×24	1	1	1
2	13603014	摆压脚提升轴后套	Presser lifting shaft back bushing	1	1	1
3	135515008	螺钉 SM15/64×28×6	Screw SM15/64×28×6	3	3	3
4	13603028	摆压脚提升中轴套	Presser lifting shaft bushing	1	1	1
5	13603013	摆压脚提升轴前套	Presser lifting shaft bushing	1	1	1
6	135530007	螺钉 SM9/32×28	Screw SM9/32×28	1	1	1
7	135516006	螺母 SM9/32×28	Nut SM9/32×28	2	2	2
8	13512018	摆压脚调压螺钉架	Lifting presser bracket for spring	1	1	1
9	101511008	螺钉 SM11/64×40×8	Screw SM11/64×40×8	4	4	4
10	14727013	摆压脚调压杆弹簧	Lifting presser spring	1	1	1
11	1350202100	调压杆弹簧导柱	Presser spring guide	1	1	1
11-1	13502026	调压杆弹簧导柱杆	Presser spring guide rod	1	1	1
11-2	13502027	调压杆弹簧导柱套	Presser spring guide bushing	1	1	1
12	201511012	螺钉 SM9/64X40	Screw SM9/64X40	4	4	4
13	114712011	提升压脚导柱架	Lifting presser guide plate assembly	1	1	1
14	402513011	螺钉 SM15/64×28×18	Screw SM15/64×28×18	1	1	1
15	1420900400	摆动轴左曲柄调节柱组件	Crank shaft complete assembly	1	1	1
15-1	142530011	摆动轴左曲柄调节柱	Crank shaft complete	1	1	1
15-2	14209004	曲柄调节柱滑块	Slide block	1	1	1
15-3	H05029	开口挡圈	Split ring	1	1	1
16	13504020	压脚摆动前曲柄	Presser swing shaft	1	1	1
17	11628005	拾牙叉固定螺钉垫圈	Washer	1	1	1
18	135516005	螺母 SM1/4×24	Nut SM1/4×24	1	1	1
19	1350401500	压脚升降前曲柄组件	Presser lifting crank	1	1	1
19-1	113602001	压脚升降轴	Presser lifting crank	1	1	1
19-2	13526007	圆锥销	Taper pin	1	1	1
19-3	13504009	压脚升降前曲柄	Pressure foot lifting shaft	1	1	1
20	135516004	螺母 SM1/4×40	Nut SM1/4×40	2	2	2
21	13505027	压脚送料曲柄连杆(加轴承)	Presser feed crank link	1	1	1
22	135520012	螺钉 SM1/4×40	Screw SM1/4×40	1	1	1
23	10124001	滚针轴承	Needle bearing	4	4	4
24	13509004	提升压脚导位板	Lifting presser plate	1	1	1
25	1147NS30002	送料曲柄导柱轴	Guide shaft	1	1	1
26	13508004	提升压脚导柱轴滚柱	Needle of bearing	1	1	1

5.上送料部件/Upper feed Parts

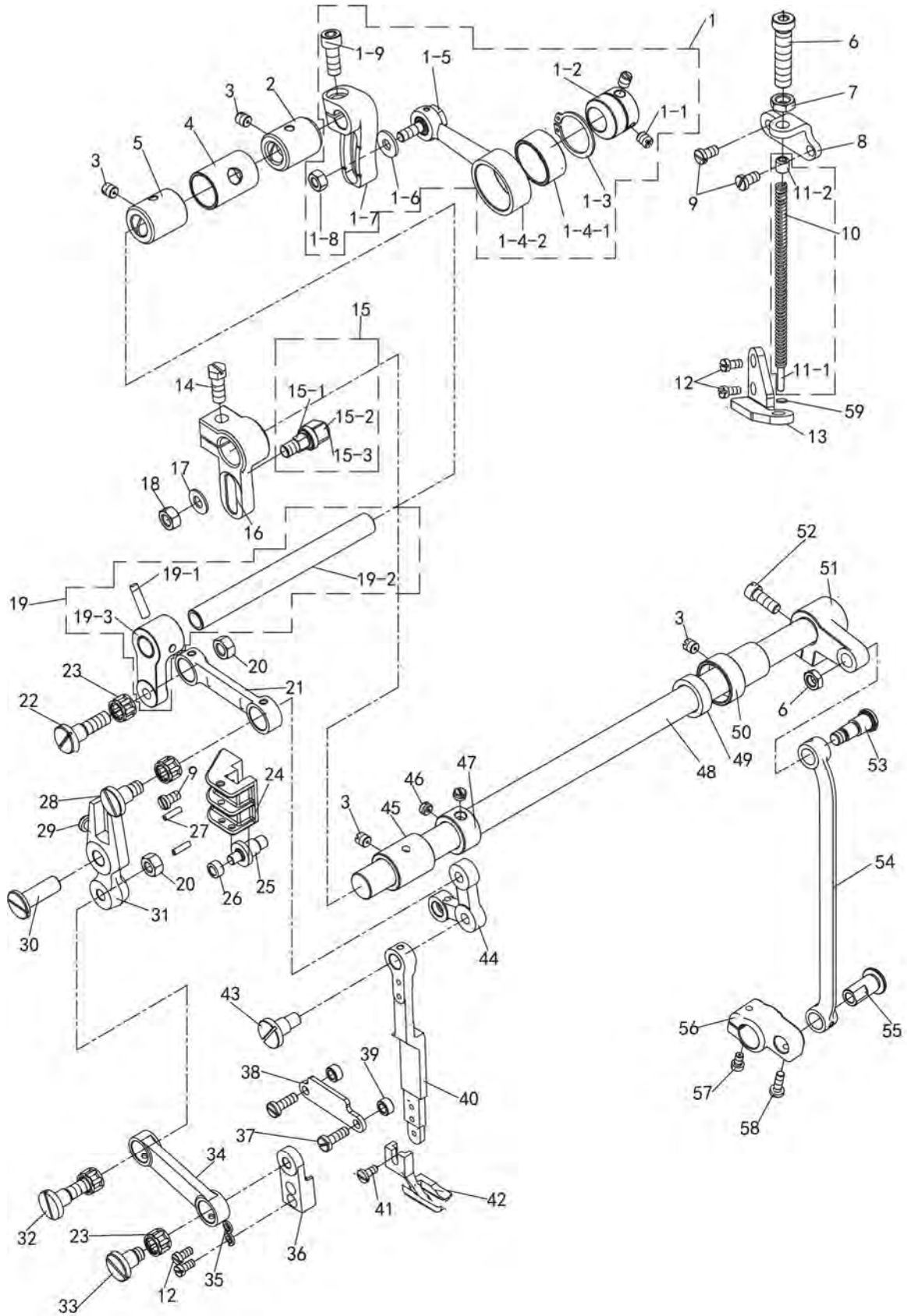

5.上送料部件/Upper feed Parts

序号 NO.	公司件号 Part NO.	名称 PartName	零件描述 Description	数量 Number		
				CZ	CZZD	CZ-12
27	P03035	弹性圆柱销 3X8	Spring round pin3X8	2	2	2
28	1147NS20001	螺钉 SM1/4×40×7	Screw SM1/4×40×7	1	1	1
29	101S11001	螺钉 SM3/16X28 L=9	Screw SM3/16X28 L=9	1	1	1
30	13526006	摆压脚叉形杆销	Pin	1	1	1
31	13505030	摆压脚叉形杆(加轴承)	Fork lever	1	1	1
32	135S20013	螺钉 SM1/4×40	Screw SM1/4×40	1	1	1
33	135S20014	螺钉 SM1/4×40	Screw SM1/4×40	1	1	1
34	13505028	摆压脚连杆 (加轴承)	Link of walking foot	1	1	1
35	W02002	垫圈 4	Washer	2	2	2
36	13601015	摆压脚杆座	Holder for walking foot bar	1	1	1
37	116s11005	螺钉 SM11/64×40×13	Screw SM11/64×40×13	2	2	2
38	114712020	提升压脚连接压板	Lifting presser sway crank guide pin	1	1	1
39	114708001	压脚连杆压板垫块	Shim	2	2	2
40	13501006	摆压脚杆	Presser rod guide	1	1	1
41	135S11030	螺钉 SM9/64×40	Screw SM9/64×40	1	1	1
42	13516002	摆压脚	Walking foot	1		1
	13516006	摆压脚	Walking foot		1	
43	1147NS20002	螺钉 SM1/4×40	Screw SM1/4×40	1	1	1
44	114704001	压脚送料曲柄(加轴承)	Presser feed crank	1	1	1
45	13508008	压脚摆动轴前轴套	Presser swing shaft front bushing (left)	1	1	1
46	135S15004	螺钉 SM1/4×40×4	Screw SM1/4×40×4	2	2	2
47	13508009	紧圈	Shaft washer	1	1	1
48	13502023	压脚摆动轴	Presser swing shaft	1	1	1
49	11472200200	摆动轴后套油封	Oil seal	1	1	1
50	13503014	压脚摆动轴中轴套	Presser swing middle shaft bushing	1	1	1
51	13504023	压脚摆动后曲柄	Presser swing crank(right)	1	1	1
52	402S13011	螺钉 SM15/64×28×18	Screw SM15/64×28×18	1	1	1
53	135S20005	螺钉 SM9/32×28	Screw SM9/32×28	1	1	1
54	13505014	摆压脚大连杆	Presser swing crank(right)rod	1	1	1
55	135S20004	大连杆曲柄连接销	Pin	1	1	1
56	13504022	送布轴曲柄 (中)	Feed rocker shaft crank middle	1	1	1
57	101S11025	螺钉 SM11/64×40×7	Screw SM11/64×40×7	1	1	1
58	116S11005	螺钉 SM11/64×40×13	Screw SM11/64×40×13	1	1	1
59	W01002	M3 垫片	Washer	1	1	1

6. 旋梭部件/Hook components

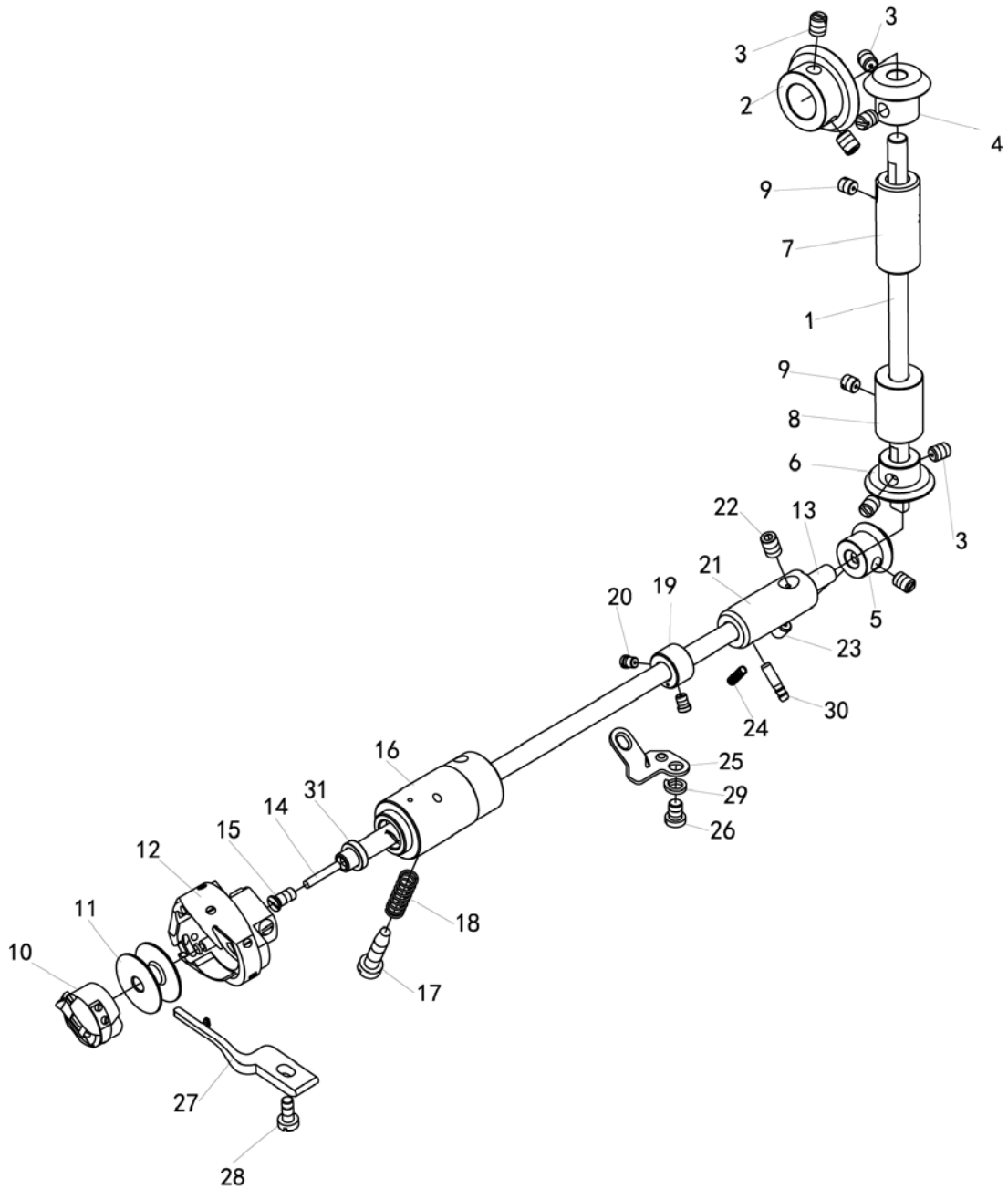

6.旋梭部件/Hook components

序号 NO.	公司件号 Part NO.	名称 Part Name	零件描述 Description	数量 Number		
				CZ	CZZD	CZ-12
1	13502002	竖轴	Upright shaft	1	1	1
2	13525001	上轴伞齿轮	Gear assembly	1	1	1
3	101s15007	螺钉 SM1/4×40×8	Screw SM1/4×40×8	8	8	8
4	13525002	竖轴伞齿轮 (上)	Gear	1	1	1
5	13525003	下轴伞齿轮	Pinion	1	1	1
6	13525004	竖轴伞齿轮 (下)	Gear	1	1	1
7	13503018	竖轴轴套 (上)	Bushing upper	1	1	1
8	13503019	竖轴轴套(下)	Up ring shaft bushing lower	1	1	1
9	135S15008	螺钉 SM15/64×28	Screw SM15/64×28	2	2	2
10	10818502	梭心套组件	Hook assembly	1	1	1
11	10818501	梭芯	Bobbin	1	1	1
12	10818001	旋梭(有尾)	Hook assembly (with tail)	1	1	1
13	13502007	下轴	Hook driving shaft	1	1	1
14	10123003	下轴滤油塞	Oil wick	1	1	1
15	135S20007	螺钉 SM3/16×32	Screw SM3/16×32	1	1	1
16	13503009	下轴前轴套	Bushing front	1	1	1
17	135S20008	螺钉 SM15/64×28	Screw SM15/64×28	1	1	1
18	13527005	油量调节弹簧	Spring	1	1	1
19	10108002	下轴紧圈	Thrust shrink collar	1	1	1
20	101S11012	螺钉 SM11/64×40×4.8	Screw SM11/64×40×4.8	2	2	2
21	13603025	下轴后轴套	Bushing rear	1	1	1
22	135S15009	螺钉 SM15/64×28	Screw SM15/64×28	1	1	1
23	13502008	柱塞	Plunger	1	1	1
24	13527006	柱塞弹簧	Plunger spring	1	1	1
25	13512009	档板	Guide plate	1	1	1
26	135S11019	螺钉 SM15/64×28	Screw SM15/64×28	1	1	1
27	13612005	旋梭定位勾	Rotating hook positioner	1	1	1
28	101S11011	螺钉	Screw	1	1	1
29	W02004	档板螺钉弹簧垫圈	Washer	1	1	1
30	13521001	下轴轴套 13612001	Oil pipe for hook shaft bushin	1	1	1
31	10122015	下轴油封	Plunger	1	1	1

7. 润滑、供油部件/Oil lubrication components

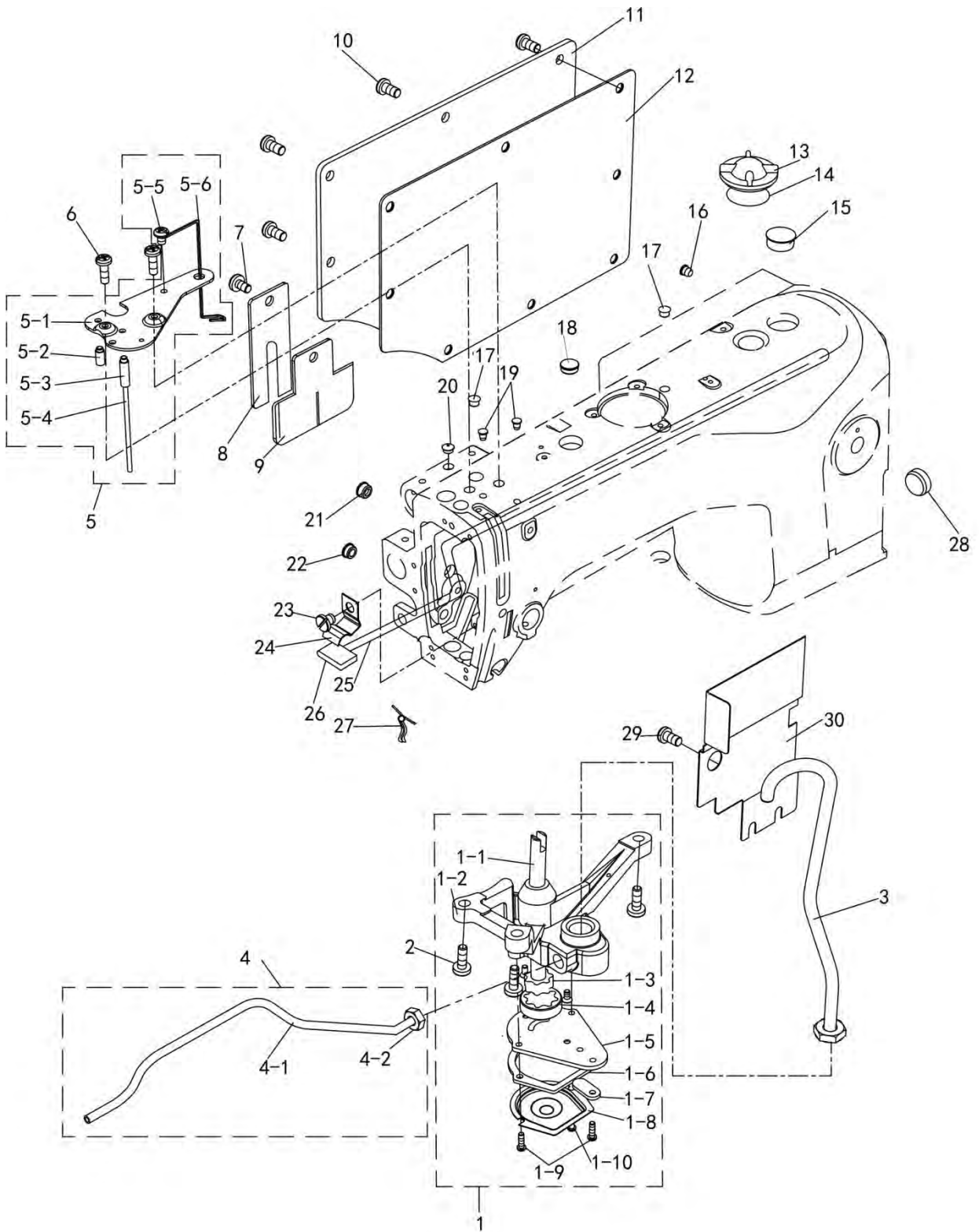

7. 润滑、供油部件/Oil lubrication components

序号 NO.	公司件号 Part NO.	名称 Part Name	零件描述 Description	数量 Number		
				CZ	CZZD	CZ-12
1	1352000200	油泵组件	Oil pump assembly	1	1	1
1-1	13502024	油泵体短轴	Shaft for oil pump	1	1	1
1-2	13520001	油泵体	Oil pump	1	1	1
1-3	13525006	油泵小齿轮	Small gear for oil pump	1	1	1
1-4	13525005	油泵大齿轮	Big gear for oil pump	1	1	1
1-5	13512021	油泵体盖板	Cover for oil pump	1	1	1
1-6	13512024	油泵滤网	Oil pump Filter	1	1	1
1-7	13512022	油泵调节板	Adjusting plate for oil pump	1	1	1
1-8	13512023	油泵滤网盖板	Oil pump Filter cover	1	1	1
1-9	S02032	油泵体盖板螺钉 M3×6	Screw M3×6	2	2	2
1-10	135511037	螺钉 M3×10	Screw M3×10	3	3	3
2	105511019	螺钉 SM11/64×40×13	Screw SM11/64×40×13	2	2	2
3	1352100700	上轴油管组件	Oil pipe complete for upper shaft	1	1	1
4	1362100100	下轴油管组件	Oil pipe for arm lower shaft	1	1	1
4-1	13621001	下轴油管	Oil pipe for lower shaft	1	1	1
4-2	13636001	下轴油管接头	Lower shaft Hose connector	1	1	1
5	1351202400	油线固定板大组件	Oil wick set plate complete	1	1	1
5-1	13512031	油线固定板	Oil line fixing plate	1	1	1
5-2	13521006	油线固定板油管(短)	Oil line fixing plate oil pipe(short)	1	1	1
5-3	13521005	油线固定板油管(长)	Oil line fixing plate oil pipe(long)	1	1	1
5-4	13523007	油线固定板油线	Oil line fixing plate oil line	1	1	1
5-5	101501010	复合槽螺钉 SM9/64×40	Screw SM9/64×40	1	1	1
5-6	13534001	油线固定勾	Oil line fixing hook	1	1	1
6	101511010	螺钉 SM9/64×40×11	Screw SM9/64×40×11	2	2	2
7	101511004	螺钉 SM3/16X28 X7	Screw SM3/16X28 X7	1	1	1
8	305102	小挡油板	Keep off plate	1	1	1
9	14722011	小挡油板羊毛毡	Keep off plate wool felt	1	1	1
10	101511001	螺钉 SM3/16X28×9	Screw SM3/16X28×9	8	8	8
11	304715	后盖板	Side plate	1	1	1
12	14722006	后盖板密封垫片	Gasket	1	1	1
13	10111004	油窗	Oil sight window	1	1	1
14	10122019	油窗 O 型圈	O-ring	1	1	1
15	13522008	橡皮塞 (φ 25.5)	Rubber plug (φ 25.5)	1	1	1
16	13522003	橡皮塞 (φ8.8)	Rubber plug (φ8.8)	1	1	1
17	10122005	挑线连杆销螺孔塞	Take-up link pin screw plug	1	1	1
18	13522001	面板橡皮塞 (φ 19)	Rubber plug (φ 19)	1	1	1
19	13522005	橡皮塞 (φ 5.7)	Rubber plug (φ 5.7)	2	2	2
20	14022013	A45-0754 孔塞 (φ8.5)	Rubber plug (φ8.5)	1	1	1
21	12922001	橡皮塞 (φ 12.5)	Rubber plug (φ 12.5)	1	1	1
22	13522002	面板橡皮塞 (φ 11.8)	Rubber plug(φ 11.8)	1	1	1
23	201511014	螺钉 SM11/64X40	Screw SM11/64X40	1	1	1
24	13512025	回油管夹	Pipe return pipe clamp	1	1	1
25	12921002	回油管 φ 3X φ 4	Oil return pipe φ 3X φ 4	1	1	1
26	13523003	回油管滤油毡	Oil felt	1	1	1
27	10423005	油线 2.5x260/2.5x290	Oil wick	1	1	1
28	13522004	橡皮塞 (φ 27)	Rubber plug (φ 27)	1	1	1
29	112511014	螺钉 SM11/64×40×5.3	Screw SM11/64×40×5.3	2	2	2
30	13612023	挡油板	Keep off plate	1	1	1

8. 开关组件/Switch components

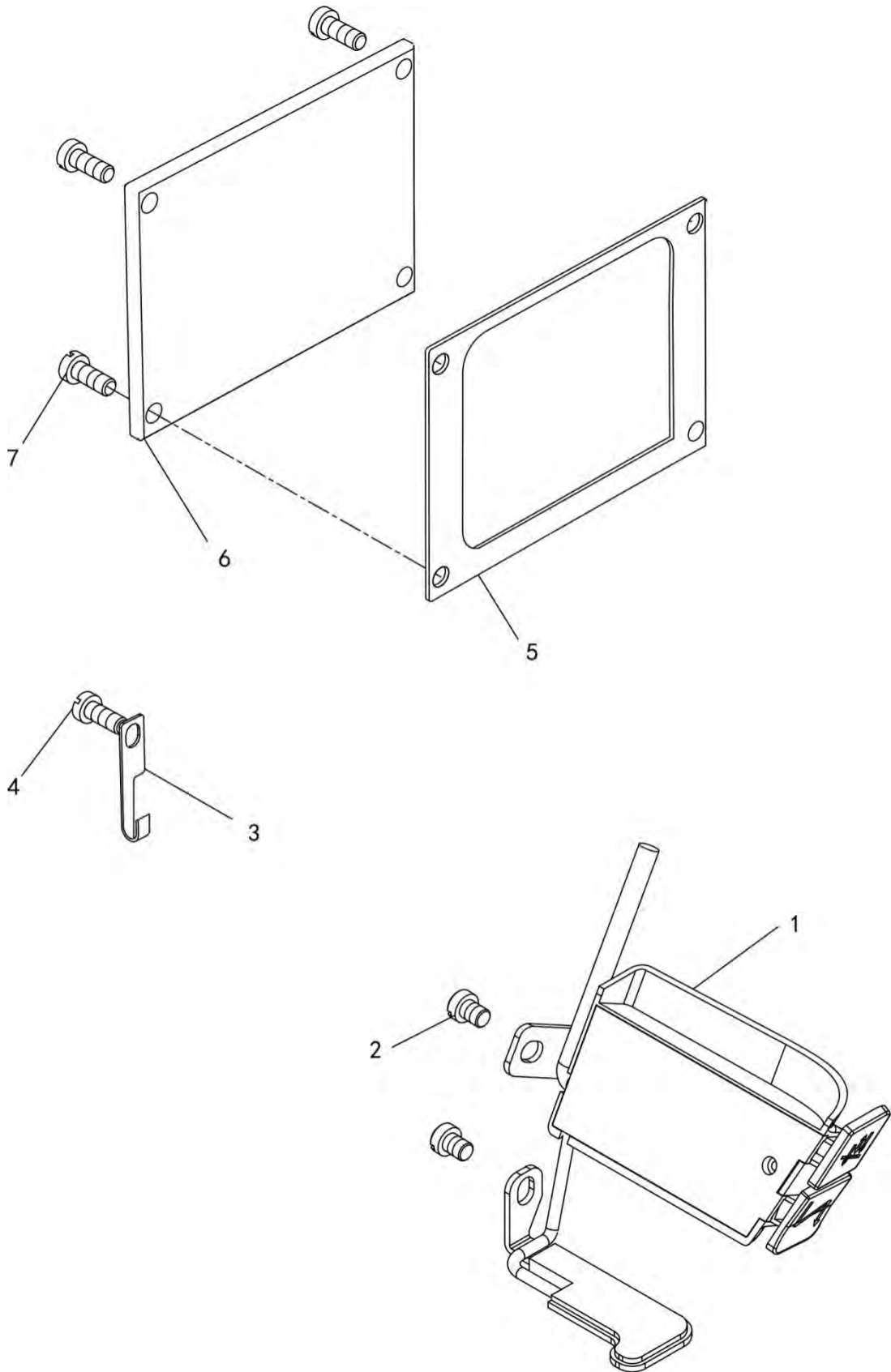

8.开关组件/Switch components

序号	公司件号 Part NO.	名称 Part Name	零件描述 Description	数量 Number		
				CZ	CZZD	CZ-12
1	1473000900	LED 灯开关组件	Switch assembly	1	1	1
2	101S11004	螺钉 SM3/16X28 X7	Screw SM3/16X28 X7	2	2	2
3	40112091	油管固定架	Oil tube holder	1	1	1
4	101S11005	螺钉	Screw	1	1	1
5	13628009	倒缝电磁铁罩垫片	Seals washer	1	1	1
6	302662	倒缝电磁铁罩	Backstitch solenoid cover	1	1	1
7	101S11001	螺钉	Screw	4	4	4

9.机头附件/Machine head accessories

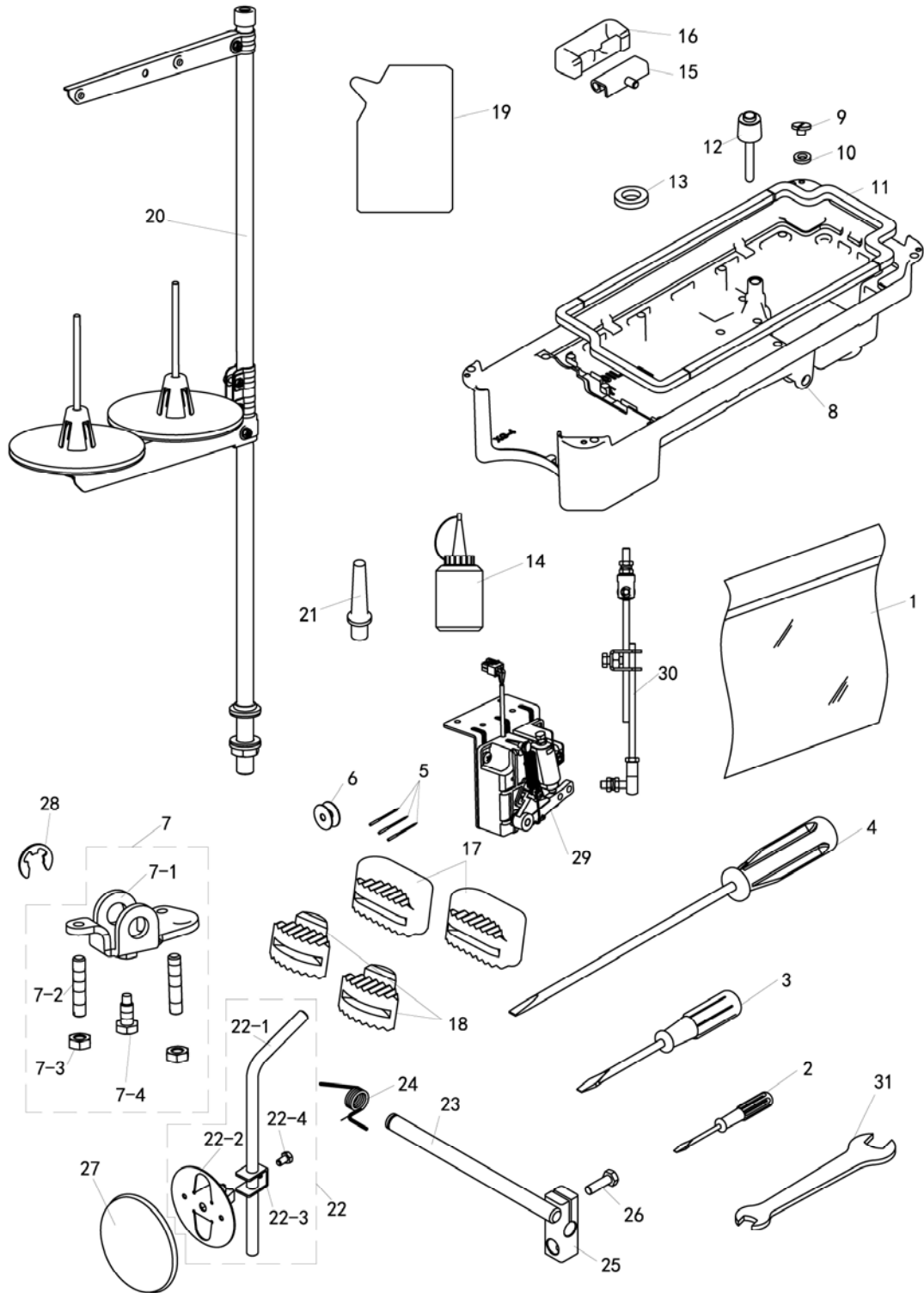

9.机头附件/Machine head accessories

序号 NO.	公司件号 Part NO.	名称 Part Name	零件描述 Description	数量 Number		
				CZ	CZZD	CZ-12
1	115031022	A5-1311 防尘罩	Machine head cover	1	1	1
2	10131004	螺钉起子 (小)	Screw driver(small)	1	1	1
3	10131003	螺钉起子 (中)	Screw driver(middle)	1	1	1
4	20731047	螺丝刀	Screw driver(large)	1	1	1
5	13517002	机针 DP×17 23#(国产)	Needle(DP×17 23#)	10	10	10
6	10818501	梭芯	Bobbin	5	5	5
7	1351203700	膝控限位架组件	Knee control limit frame	1	1	1
7-1	13512026	膝控限位架	Knee lifter stop bracket	1	1	1
7-2	135515019	膝控限位调节螺钉 M6	Screw M6	2	2	2
7-3	N01029	调节螺母 M6	Nut M6	2	2	2
7-4	135512003	膝控限位架螺钉 M6	Screw M6	1	1	1
	1350100900	油盘组件	Oil pan assembly	1	1	1
8	13501007	油盘	Oil reservoir	1	1	1
9	101511028	放油螺钉 SM5/16×24×7	Screw SM5/16×24×7	1	1	1
10	001047	放油螺钉垫圈	Washer	1	1	1
11	13523006	油盘垫	Gasket	1	1	1
12	13511006	膝控提升顶杆	Knee press lifter rod	1	1	1
13	10131001	磁块	Magnet	1	1	1
14	20131038	小油壶	Oil pot	1	1	1
15	10122060	机壳铰链	Rubber coat	2	2	2
16	1011203100	机壳铰链套	Hinge	2	2	2
17	113522001	机头防震垫块 (大)	Cushion(big)	2	2	2
18	10122022	机头防震垫块 (小)	Cushion(small)	2	2	2
19	113511001	油袋(600ml)(10#)	Oil bag (600ml)(10#)	1	1	1
20	1383100300	线架组件	Spool stand complete	1	1	1
21	10111011	机头支柱	Frame support bar	1	1	1
22	1351203800	膝控操纵杆组件	Joystick assembly	1	1	1
22-1	13512038	膝控碰块弯杆	Bent rod	1	1	1
22-2	10112029	膝控碰块	Bell	1	1	1
22-3	10112030	碰块架	Bell bracket	1	1	1
22-4	101s12004	碰块架螺钉 M6×11	Screw M6×11	1	1	1
23	13502025	膝控铰链轴	Hinge pin	1	1	1
24	13527014	膝控复位弹簧	Spring	1	1	1
25	10101008	碰块弯杆接头	Connector	1	1	1
26	101s12003	螺钉 M8	Screw M8	2	2	2
27	10122024	碰块垫	Mat	1	1	1
28	H05010	开口挡圈	Split stop ring	1	1	1
29	11023001700	电控脚踏	Electric control pedal	1	1	1
	703725	包材	Packaging materials	1	1	1
30	11543100300	脚踏连杆	Pedal connecting rod	1	1	1
31	114712003	开口扳手(14-10)	Open wrench	1	1	1

成套智联 让服装智造无限可能



杰克股份官方微信



杰克股份官方抖音



杰克资料库



参观杰克

400-8876-858
www.chinajack.com

杰克科技股份有限公司
浙江省台州市椒江区东海大道东段1008号
电话 :0086-576-88177788 88177789
传真 :0086-576-88177758

JACK TECHNOLOGY CO.,LTD
No.1008, Donghai Road East, Jiaojiang District,
Taizhou city, Zhejiang, China
TEL:0086-576-88177788 88177789
FAX:0086-576-88177758
